

# Ball / Land Grid Array Sockets

## KnobLock Type



**E-tec is now the leading BGA socket manufacturer.**

EP patents 0829188, 0897655 US patents 6190181, 6249440 Patented in other countries.

KnobLock sockets are designed for easy handling and where a high number of chips insertion / extraction cycles is required. The SMT socket is simply placed and reflowed onto the PCB in the same way as the chip and occupies only a small amount of additional board space. The 1.27mm pitch KnobLock socket extends  $\approx$  6.00mm beyond the outer ball row with no fixing holes. Not all grid sizes and pitches are available in KnobLock style and in some cases a mechanical attachment to the PCB may be required. Therefore always contact E-tec for availability first.

We aim to solve your requirements - many different terminals and configurations are available. Your custom sets our standards!

**Please note, we will always request the chip data to ensure we offer a compatible socket.**

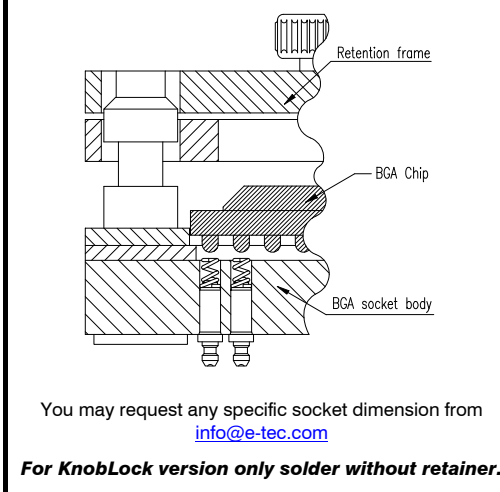
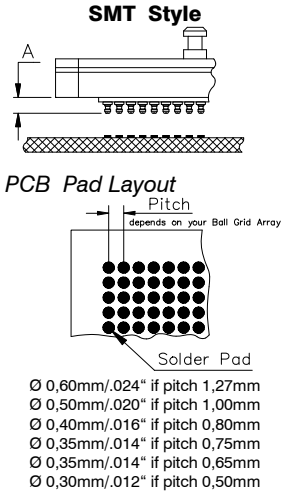
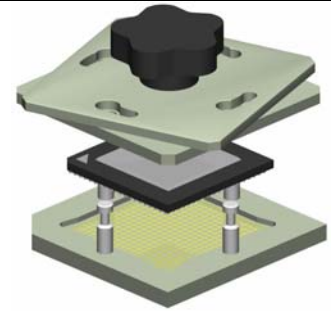

**Important Note:**

Please check the ball diameters & heights of your chip prior to ordering the standard E-tec BGA (BCK, BPK) sockets. Any deviation has to be communicated to E-tec in order to check compatibility with the standard socket design and if necessary to obtain a special order code adapted to your chip dimensions.

The standard solderball diameters & heights are the following:

Pitch	ball diameters min/max	ball height min/max
0.50mm	0.25mm / 0.35mm	0.15mm / 0.30mm
0.65mm	0.25mm / 0.45mm	0.15mm / 0.30mm
0.75mm	0.25mm / 0.45mm	0.15mm / 0.40mm
0.80mm	0.40mm / 0.55mm	0.25mm / 0.45mm
1.00mm	0.50mm / 0.70mm	0.30mm / 0.50mm

**1.27mm & 1.50mm**

- a) plastic chips (BPK) 0.60mm / 1.00mm 0.50mm / 0.70mm
- b) ceramic chips (BCK) 0.60mm / 1.00mm 0.80mm / 1.00mm

**If the minimum ball diameter of a given chip falls below the above indications, then a BUK socket will generally be proposed.**

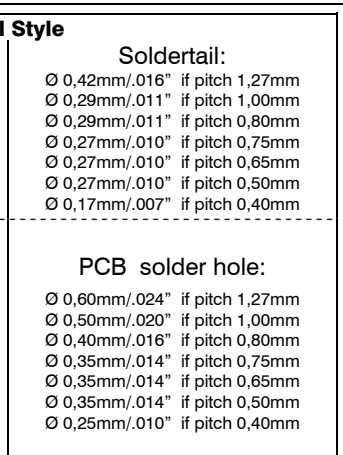
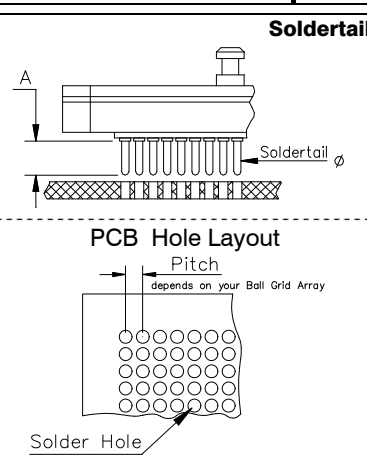

**Specifications**

Mechanical data	
Contact life	10.000 cycles min.
Retention system life	10.000 cycles min.
Solderability	as per IEC 60068-2-58
Individual contact force	40 grams max.
Material	
Insulator (RoHS compliant)	High temp plastic or epoxy FR4
Terminal (RoHS compliant)	Brass
Contact (RoHS compliant)	BeCu
Electrical data	
Contact resistance	< 100 m $\Omega$
Current rating	500 mA max.
Insulation resistance at 500V DC	100 M $\Omega$ if 0.50 to 0.80mm pitch 500 M $\Omega$ 1.00mm pitch upwards
Breakdown voltage at 60 Hz	500V min.
Capacitance	< 1 pF
Inductance	< 2 nH
Operating temperature	-55°C to +125°C ; 260°C for 60 sec.

**Recommendations:** Solder paste – Please use a solder paste w/o any silver! Solder profile – Please refer to our website [www.e-tec.com](http://www.e-tec.com)

E-tec solderless sockets are adapted to a standard PCB thickness of 1.60mm. For a different PCB thickness, please inform E-tec first!

SMT KnobLock Sockets are recommended to be ordered with locating pegs for soldering to the PCB, to avoid the solderjoints from being stressed due to the torque forces applied with this locking system. If used without locating pegs, the life cycle of the socket may be heavily reduced.

For high pincount SMT sockets, E-tec recommends the use of a pluggable thru-hole socket mounted into a MiniGrid Adapter (see also pages 15, 16 & 16a for more details).

**How to order**

**X X K** **x x x x** - **x x** **x x** - **x x** **X X** **x x** **L** ← optional for locating pegs

<p><b>Device Type</b></p> <p><b>B</b> = Ball Grid</p> <p><b>L</b> = Land Grid</p> <p><b>C</b> = Column Grid</p>	<p><b>Device Material</b></p> <p><b>C</b> = std. socket for ceramic device</p> <p><b>P</b> = std. socket for plastic device</p> <p><b>U</b> = socket adapted to small diameter solderballs</p>	<p><b>Pitch</b></p> <table border="0"> <tr> <td><b>04</b> = 0,40mm</td> <td><b>10</b> = 1,00mm</td> </tr> <tr> <td><b>05</b> = 0,50mm</td> <td><b>12</b> = 1,27mm</td> </tr> <tr> <td><b>06</b> = 0,65mm</td> <td><b>15</b> = 1,50mm</td> </tr> <tr> <td><b>07</b> = 0,75mm</td> <td></td> </tr> <tr> <td><b>08</b> = 0,80mm</td> <td>others on request</td> </tr> </table>	<b>04</b> = 0,40mm	<b>10</b> = 1,00mm	<b>05</b> = 0,50mm	<b>12</b> = 1,27mm	<b>06</b> = 0,65mm	<b>15</b> = 1,50mm	<b>07</b> = 0,75mm		<b>08</b> = 0,80mm	others on request	<p><b>Grid Code</b>   <b>Config Code</b></p> <p>will be given by the factory after receipt of the chip datasheet</p>	<p><b>Plating</b></p> <p><b>95</b> = tin/gold (tin leadfree)</p> <p><b>55</b> = gold only for solderless Compression Type</p>
<b>04</b> = 0,40mm	<b>10</b> = 1,00mm													
<b>05</b> = 0,50mm	<b>12</b> = 1,27mm													
<b>06</b> = 0,65mm	<b>15</b> = 1,50mm													
<b>07</b> = 0,75mm														
<b>08</b> = 0,80mm	others on request													

<p><b>Nbr of contacts</b></p> <p>Depends on ballcount of chip. For chips with ballcount &lt; 100 please contact E-tec for availability first.</p>	<p><b>Contact Type</b></p> <p><b>30</b> = standard SMT.... („A“ = 1,20mm if 1,27mm pitch; 0,80mm if 1,00mm pitch, 0,60 if 0,80mm pitch; 0,40mm if &lt;0.80mm pitch)</p> <p><b>29</b> = raised SMT.... („A“ = 5,00mm if 1,27mm pitch; 3,20mm if 1,00mm pitch; 2,80mm if 0,80mm pitch, 2,30mm if &lt;0.80mm pitch)</p> <p><b>28</b> = special raised SMT - only for 1.00 &amp; 0.80mm pitch..... („A“ = 4,50mm)</p> <p><b>70</b> = standard solder tail..... („A“ = 3,30 if 1.27mm pitch, 2.80 if 1.00mm or 0.80mm pitch, 2,30mm if &lt;0.80mm pitch)</p> <p><b>90</b> = solderless Compression Type (see page 13 for more details)</p>
---	---