



### E-tec is now the leading BGA socket manufacturer.

These elastomer interposer sockets are available for any chip size and pitch. The standard version is the solderless socket style, which is attached with 2 or 4 screws to the PCB. SMT and thru-hole adapter sockets are also available with these elastomer interposers to allow using this high frequency interposer on PCB's which have already been laid out for SMT or thru-hole sockets. The retainer can be delivered with a center opening for die access and the socket outline will be kept to a minimum and special clearances can be offered to avoid components on the PCB.

We aim to solve your requirements - your custom sets our standards!

**Please note, we will always request the chip data to ensure we offer a compatible socket.**

BGA/LGA/QFN Chip Socket

GullWing Chip Socket

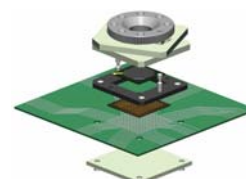

FastLock Type

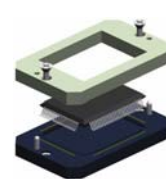

ScrewLock Type

### Solderless Compression style Standard Version

(FastLock Type as example only - other locking systems available also)

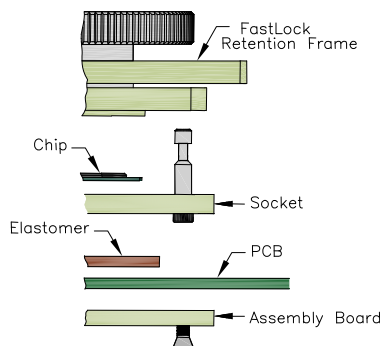
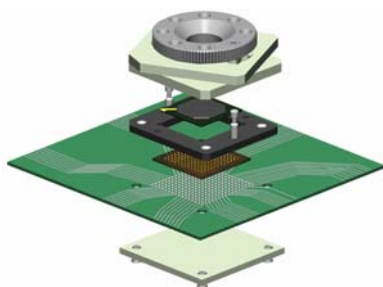

- gold plated pads Ø 0,70mm/.027" if pitch 1,27mm
- gold plated pads Ø 0,60mm/.024" if pitch 1,00mm
- gold plated pads Ø 0,50mm/.020" if pitch 0,80mm
- gold plated pads Ø 0,45mm/.018" if pitch 0,75mm
- gold plated pads Ø 0,40mm/.016" if pitch 0,65mm
- gold plated pads Ø 0,30mm/.012" if pitch 0,50mm

#### Important Note:

PCB pad height: same or higher then solder mask.  
PCB thickness: 1.60mm std. (others: contact E-tec)

### Elastomer Specifications

Flammability	UL 94V-0
<b>Current rating at minimum 0.10mm compression depends on solderball size:</b>	
0.30mm dia balls	1A min.
0.60mm dia balls	2A min.
Insulation resistance :	1000 MΩ
Contact resistance :	< 50 mΩ
Capacitance :	< 0.3 pF
Inductance :	< 0.6 nH
Breakdown voltage :	500V DC
Operating temperature :	-35°C to +125°C
Bandwidth	
0.50mm thick elastomer	sinusoidal signals : -1dB at >10 GHz digital signals: 10 GHz min.
1.00mm thick elastomer	sinusoidal signals: -1dB at >10 GHz digital signals: up to 6.5GHz max.
<b>Recommended Compression: 0.10mm min.</b>	
Compression forces	
0.50mm thick elastomer	Solderball diameters 0.50mm = 40 to 50gf @0.20mm 0.60mm = 60 to 80gf @0.20mm 0.75mm = 90 to 120gf @0.20mm
1.00mm thick elastomer	Solderball diameters 0.50mm = 40 to 50gf @0.20mm 0.60mm = 50 to 70gf @0.20mm 0.75mm = 90 to 120gf @0.20mm

### Mechanical data

Elastomer life	BGA chips :	1000 cycles min.
	LGA/QFN chips :	10'000 cycles min.

### Dimensions & Tolerances

Pitch of wires	P1 & P2 = 0.05mm x 0.05mm to 0.10mm x 0.10mm (depending on pitch of chip)
Thickness/Offset	T = 0.50mm (±0.05mm)/Offset = 0.25mm (±0.05mm) T = 1.00mm (±0.07mm)/Offset = 0.50mm (±0.07mm)
Width/Length	min. = 3.00mm x 3.00mm (±0.50mm) max. = 49.00mm x 49.00mm (±0.50mm)

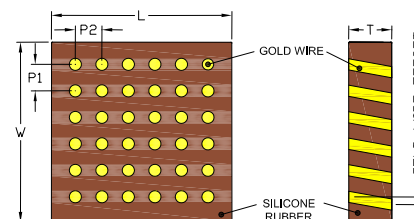

### Special Elastomer Adapters (available on request)

#### SMT Adapter Style on request

(QuickLock Type as example only - other locking systems available also)

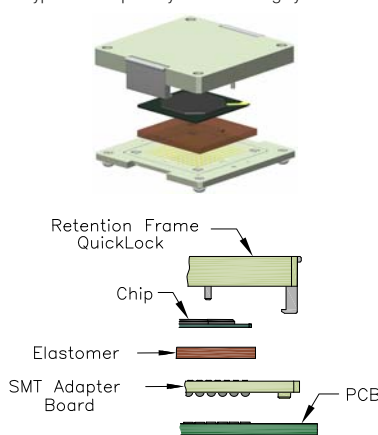

#### Recommendations for SMT Adapter Boards

Solder paste Please use a solder paste w/o any silver!  
Solder profile Please refer to our website [www.e-tec.com](http://www.e-tec.com)

#### Soldertail Adapter Style on request

(FastLock Type as example only - other locking systems available also)

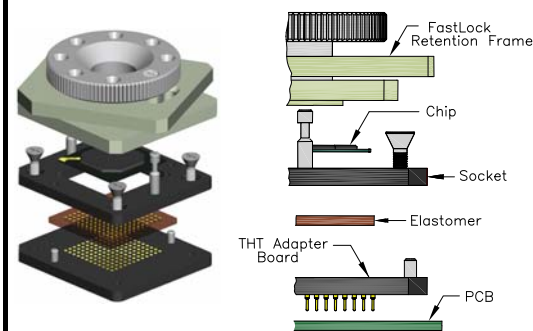

### How to order

**E X X X X X X - X X X X - X X X X X X L** ← locating pegs

Device Type	Locking Type	Nbr of contacts	Elastomer or Pitch	Grid Code	Config Code	Plating
<b>B</b> = BGA <b>L</b> = LGA/QFN <b>G</b> = GullWing	<b>F</b> = FastLock <b>W</b> = TwistLock <b>Q</b> = QuickLock <b>C</b> = ClamShell	<b>999</b> if LGA or QFN <b>Ball count</b> if BGA	<i>will be given by the factory after receipt of the chip datasheet</i>	<i>will be given by the factory after receipt of the chip datasheet</i>		<b>55</b> = gold if with adapterboard <b>95</b> = tin/gold (tin leadfree)

### Contact Type

- 90** = Solderless Compression Type; 6.5 GHz performance
- 91** = Solderless Compression Type; 10 GHz performance  
*others on request*
- Solder Adapters (on request only):**
- 30** = SMT..... (with surface mount Adapterboard)
- 70** = THT..... (with soldertail Adapterboard)